

Replace roof and convert loft to form bedrooms at 6 Vardon Drive Leigh-on-Sea

Notes
 All dimensions and/or load-bearing walls to be checked and agreed on site as correct by contractor prior to commencement of works and ordering of materials. Any discrepancies to be reported to DK Building Designs prior to commencement of works. DK Building Designs will accept no responsibility for works commenced on site prior to planning approval (if relevant) and building control approval.
 Plans are copyright and are not to be used without consent from DK Building Designs.
 If applicable, clients / contractor to liaise with neighbours to abide with party wall act etc.
 All beam calculations (if applicable) as per separate sheet. All stated spans of beams are clear spans only, between supports. Additional length to be added for end bearing of beams. Beams to cover full length of padstones.

Existing Ground
1 : 100

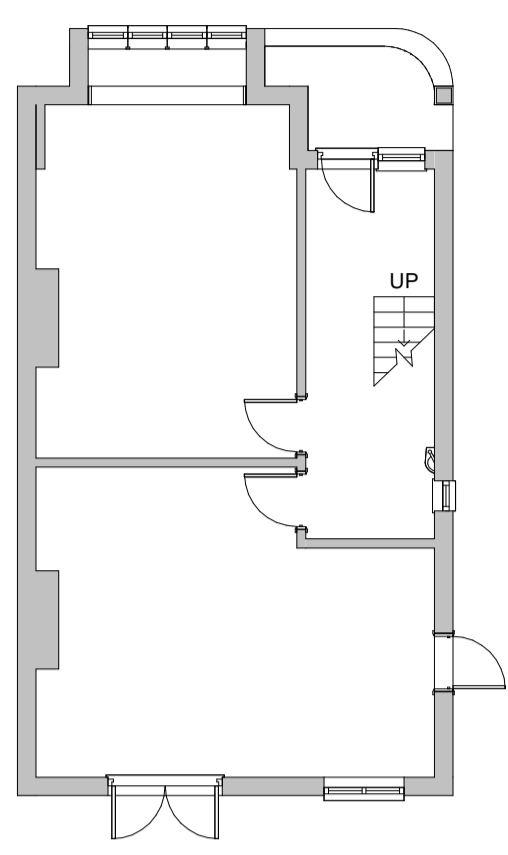

Existing First
1 : 100

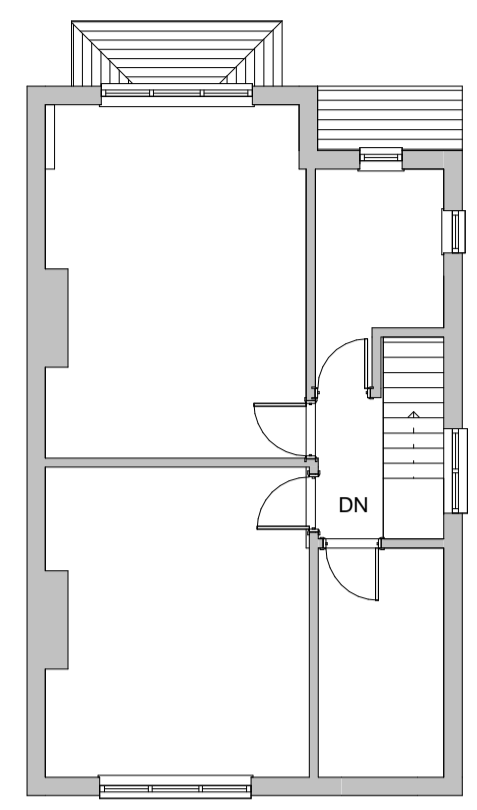

Proposed First
1 : 100

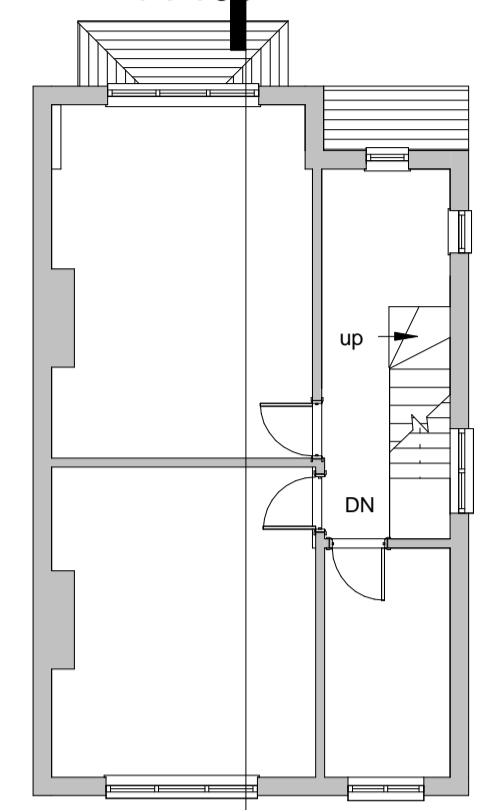

Proposed Second
1 : 100

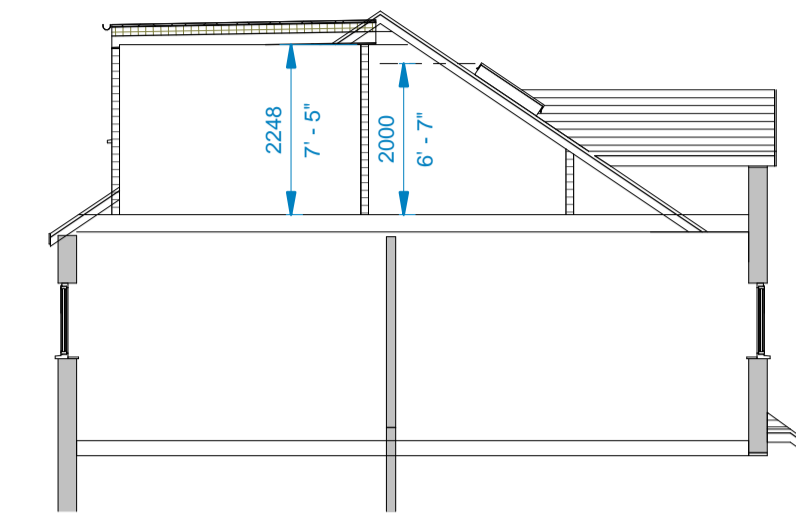
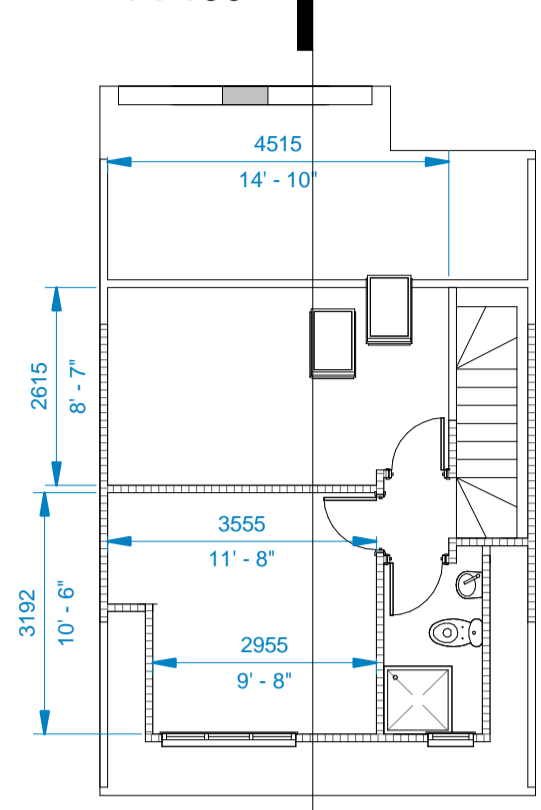

Section 1
1 : 100



Site Plan
1 : 1250

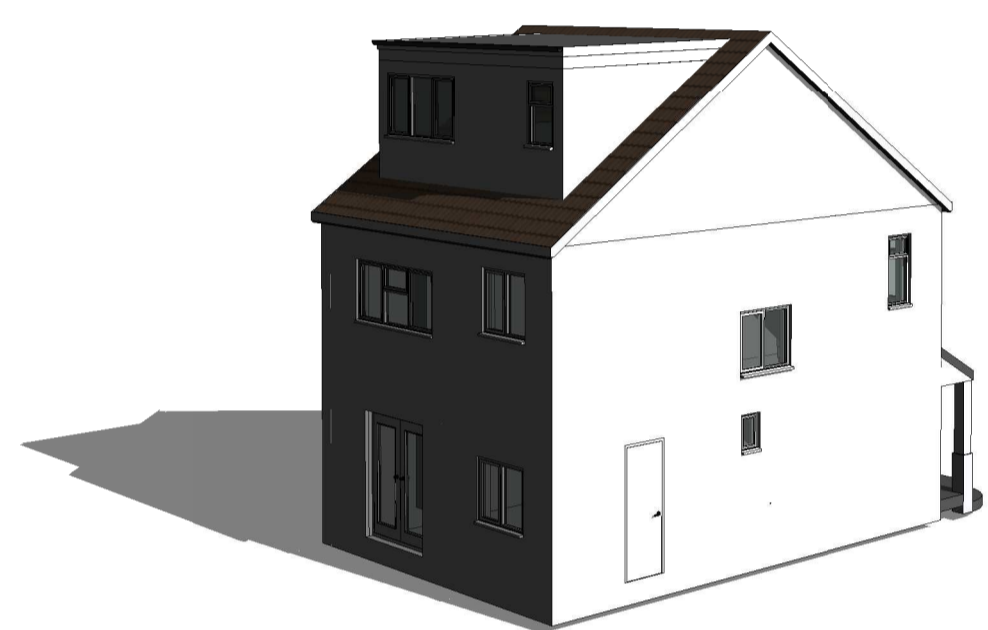

Proposed 3D View 1



Proposed 3D View 2

Proposed Front
1 : 100



Proposed Rear
1 : 100



Proposed Side L
1 : 100

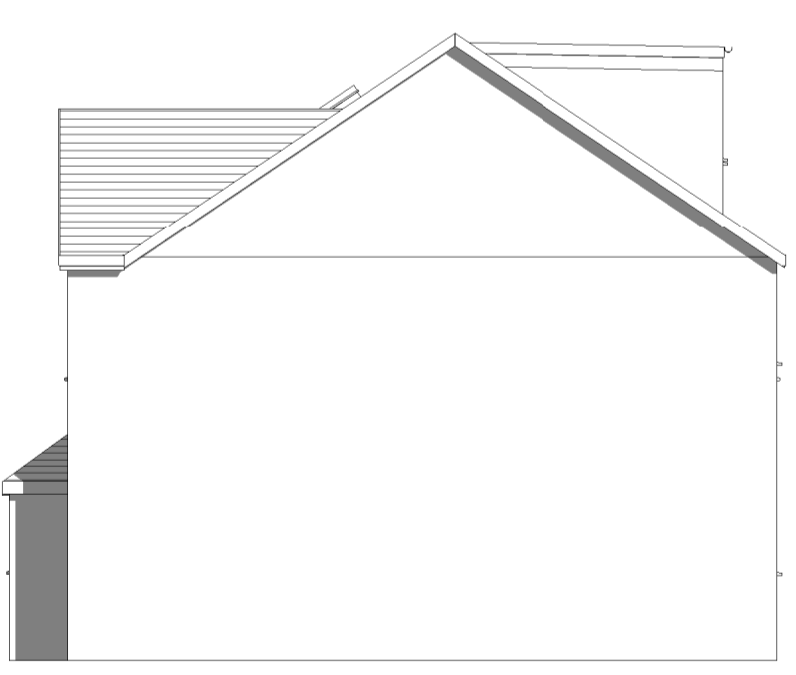

Proposed Side R
1 : 100

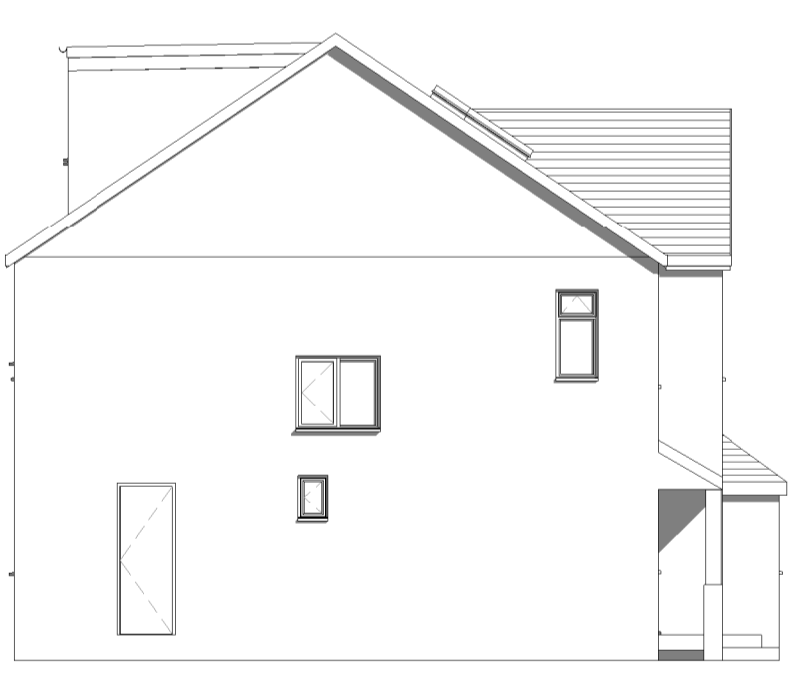

Existing Front
1 : 100



Existing Rear
1 : 100



Existing Side L
1 : 100

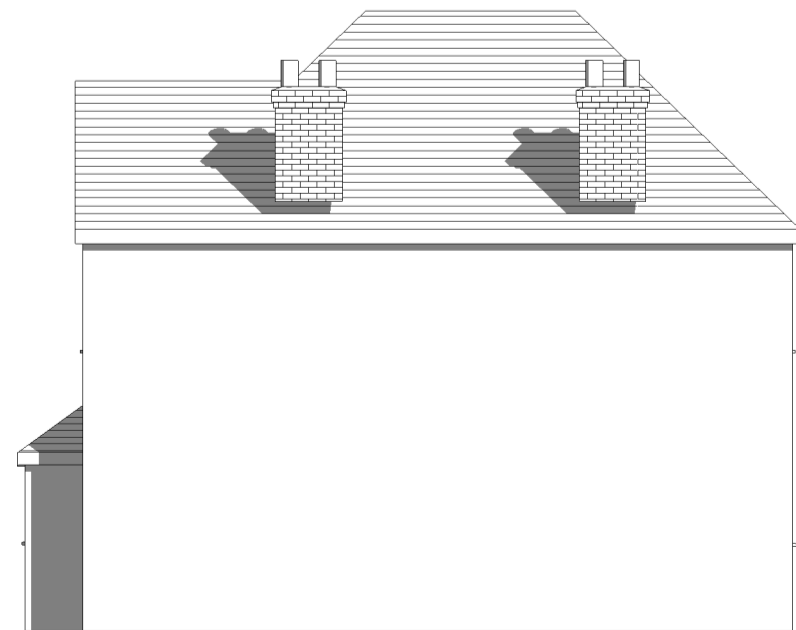

Existing Side R
1 : 100

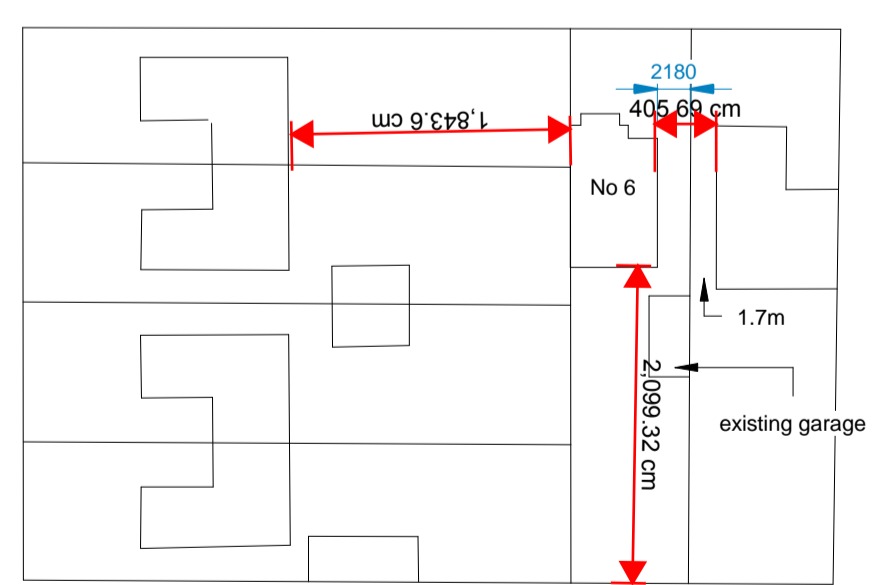
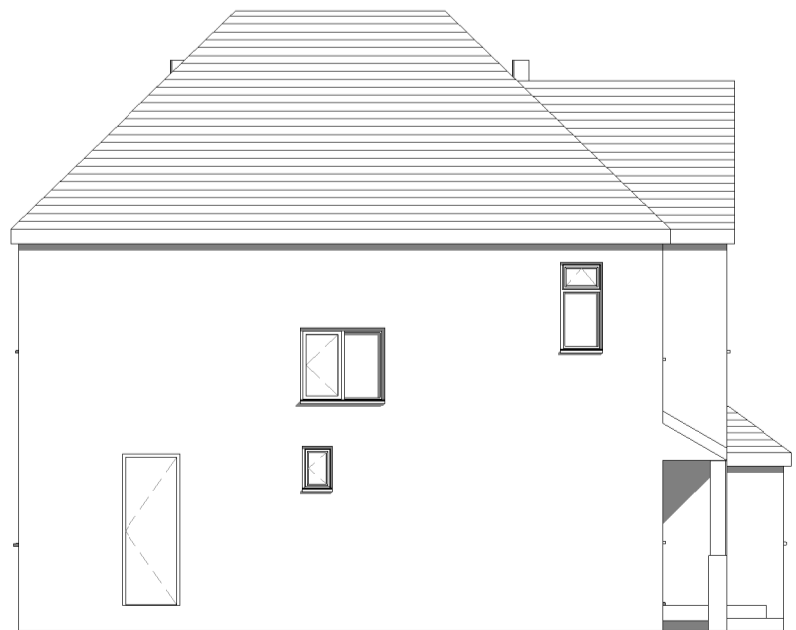

Site Plan Existing1
1 : 500